

# GASER

## TURN TABLE 1200-1500-2000

MOTORIZED ROTARY TABLES

MACHINERY FOR THE  
FOOD INDUSTRY

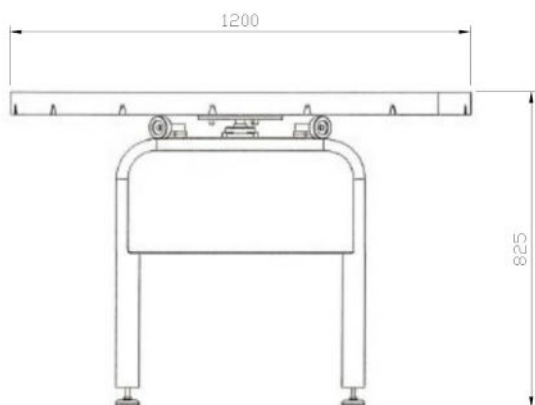

Rotary table to facilitate collection after exiting the breading machine or the frying line.

- Made of stainless steel.
- Upper working zone made of polythene for food products or stainless steel.
- Diameter at choice 1.200 mm, 1.500 mm or 2.000 mm.
- Adjustable height: 850 mm.
- Speed rotation: 10 rpm.
- Power: 0,12 kW.
- Rotary turntable 1.200 mm with polythene upper working zone.
- Rotary turntable 1.500 mm with stainless steel upper working zone.
- Rotary turntable 2.000 mm with stainless steel upper working zone.



### RELATED MACHINES:

Fryers, batter-breeding machines, Diaphragm GM-7000, Meatball and croquettes former S-1500-PC.

INDUSTRIAS GASER, S.L. - Ctra. Bescanó, 15, Pol. Torre Mirona 17190 Salt (Girona) - Spain  
Tel. +34 972 23 65 72. E-mail [export2@gaser.com](mailto:export2@gaser.com)