



THOMPSON MEAT MACHINERY



*Thompson Frozen Block
Pre-Breaker*

*Thompson Frozen
Block Flaker*

FROZEN BLOCK FLAKER & PRE-BREAKER

Thompson Frozen Block Flaker

The **Thompson Frozen Block Flaker** is a heavy duty industrial machine specifically designed to process large volumes of frozen product. It is used extensively in many high production facilities worldwide. It is renowned for **consistently delivering high performance and reliability.**

The Thompson Frozen Block Flaker is a robust machine that is built to last. **Constructed from high quality Stainless Steel**, a strong framework supports a heavy gauge feed chute and table.

The Thompson Frozen Block Flaker has been designed and developed to the high standards of safety and finish demanded by **CE/USDA and GS regulations.**

The Thompson Frozen Block Flaker is the perfect companion for the Thompson range of Mixer Mincers. **This machine can rapidly transform frozen blocks of meat or other suitable products such as frozen cheese, into flaked product.**

Eight curved blades rapidly cut scalloped pieces from the frozen block and eject them into a 200 litre bin. Due to a **unique guarding system which closes the discharge chute**, blocks can be queued and then processed without stopping while bins are being replaced.

The feed chute is electronically locked during the cutting cycle and can only be opened after the motor has been stopped and a time of 40 seconds has elapsed; this time allows the heavy **Stainless Steel Drum** to come to a complete stop. For safety, the machine cannot be restarted until the feed chute has been closed and locked. Two lights on the control panel indicate the machine's state, i.e. amber for locked and ready to process product or blue for open in preparation for cleaning.

With the aid of a pneumatic button the ram can also be stopped midway in its stroke to allow the operator to remove any product trapped behind the push bar. With the feed chute opened there is **safe and easy access to the working parts of the machine for cleaning and sanitation.**

This **machine is of robust construction** and the drum has been designed to achieve a satisfactory level of dynamic balance.

OUTSTANDING FEATURES

- Process blocks of various size up to 600 x 400 x 280mm
- Process time per block is typically 15 seconds
- Increases the performance of Mixer Mincers
- Flake sizes of 5 mm to 10 mm can be obtained (depending on the temperature of the product)
- Easy removal and replacement of cutting blades
- The drum, knives and body of the machine are manufactured from high quality stainless steel ensuring hygiene and easy cleaning.

The Perfect Companion for the Thompson Range of Frozen Mixer Mincers.



Thompson Frozen Block Pre-Breaker

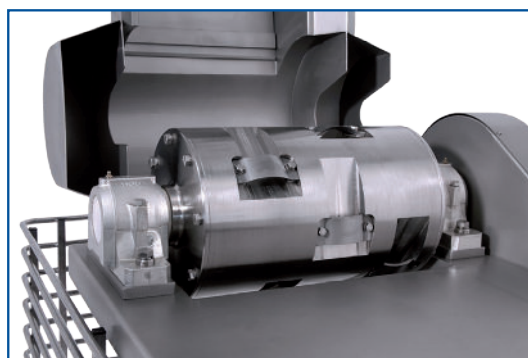

Discharge Chute with Guard Closed



Flaker Drum Assembly

Thompson Frozen Block Pre-Breaker

The **Thompson Frozen Block Pre-Breaker** is designed to break up hard and frozen food blocks including meat and dairy products **without destroying the texture of the product, eliminating the inconsistently sized particles and product emulsification.**

The Thompson Frozen Block Pre-Breaker can take any **frozen product without thawing from -15°C to -3°C saving operator's valuable time and energy.** The blocks can be processed within a remarkable 4 seconds to produce an **extraordinary production of up to 8 tonne per hour.** Maximum output of the Pre-Breaker is ensured by the **high cutting speed** of the rotor type blade mechanisms. The frozen blocks are drawn to the slow speed rotor blades with high torque cutting forces **achieving exceptional production output rate.**

The frozen meat blocks are **easy to load into the cutting area**, where they are transformed by sharp blades into slices or with cross blades into smaller cube pieces. It is **simple and safe to operate.**

The **Thompson Frozen Block Pre-Breaker** discharges product into 200L tote bins, various size tubs or onto conveyor for continuous feeding into Thompson range of Mixer Mincers for further processing. **20 tonne per hour production output** can be achieved if continually conveyor fed.

The **robust and reliable built quality** means **low maintenance and operating costs** provides years of trouble-free operation.



Thompson Frozen Block Flaker



High integrity of large pieces of processed meat



Intake Chute

FEATURES OF THE FROZEN BLOCK PRE-BREAKER:

- **High output** is ensured by the high cutting speed of the rotor type blade mechanism;
- Design of the Pre Breaking Cutting System provides **high integrity of large pieces of meat** for further processing with **reduced violation of the structure of frozen meat.**
- Pre-breaking product by drawing frozen blocks with cutting forces to the rotor blades;
- **Easy maintenance, reliability and low operating costs.**
- **Exceptional Quiet Operation** when compared with Frozen Block Flaker

Specifications

Thompson Frozen Block Flaker

Motor:	7.5 kW
Volts:	415 V
Full Load Current:	15 Amps
Air Pressure:	60 psi
Net Machine Weight:	800 kg
Ship Weight:	1000 kg
Ship Size (mm):	2500 x 1200 x 1600 H

Ideally frozen blocks of meat should be processed at a temperature of approx. -12°C (10°F) (the temperature may need to be varied, depending on the product being processed).

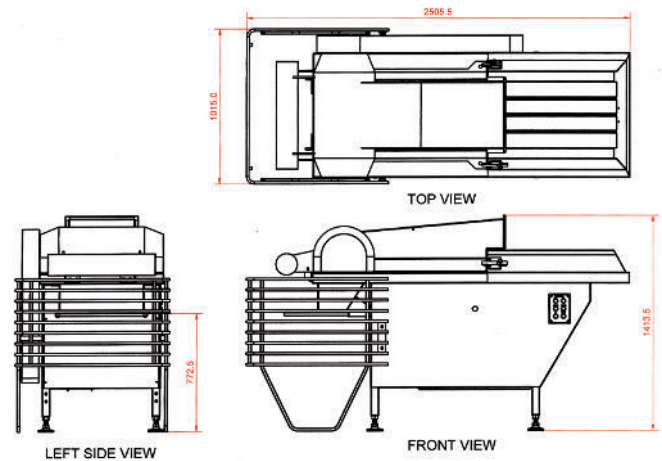

Thompson Frozen Block Pre-Breaker

Product Performance	
Production Capacity	8,000kg/h
Weight of Cut Pieces	100g - 450g
Minimum Product Block Temperature	Minus 15°C
Dimensions	
Intake Chute Height (from floor)	1,300mm
Intake Chute Depth	270mm
Dimensions of Blocks Fed (LxWxH)	600mm x 400mm x 270mm
Discharge Height	700mm
Floor Area (without service zone)	1.6m ²
Overall Dimensions (LxWxH)	1,330mm x 1,030mm x 1,630mm
Net Machine Weight	760kg
Motor / Power Supply*	
Motor	15kW
Power Supply	63 Amps
Full Load Current	30 Amps
Shipping Dimensions	
Shipping Weight	900kg
Shipping Dimension	1,480mm x 1,220mm x 1,795mm

**Machine power to be fitted with a "D" curve motor start circuit breaker.
Technical data is to be used as a guide only and is subject to change without notice. Dimensions and weights may vary in the course of development.*

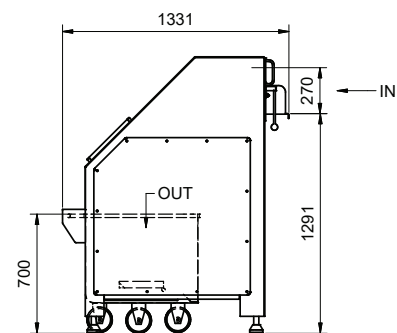
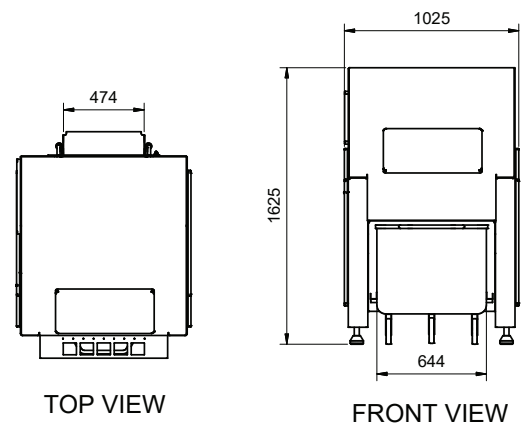

SIDE VIEW



tmach.com.au

Thompson Meat Machinery

134 Magnesium Drive,
CRESTMead QLD 4132
Australia

Email: sales@tmach.com.au
Phone: +61 7 3803 6643
Fax: +61 7 3803 6635