



# THOMPSON MEAT MACHINERY

*Frozen Block Flaker*



LEADING MANUFACTURERS OF MEAT PROCESSING MACHINERY

# THOMPSON FROZEN BLOCK FLAKER



Discharge Chute with Guard

The **Thompson Frozen Block Flaker** is a heavy duty industrial machine specifically designed to process large volumes of frozen product. It is used extensively in many high production facilities worldwide. It is renowned for **consistently delivering high performance and reliability**.

The Thompson Frozen Block Flaker is a robust machine that is built to last. **Constructed from high quality**

**Stainless Steel**, a strong framework supports a heavy gauge feed chute and table.

The Thompson Frozen Block Flaker has been designed and developed to the high standards of safety and finish demanded by **CE/USDA and GS regulations**.

The Thompson Frozen Block Flaker is the perfect companion for the Thompson range of Mixer Mincers. **This machine can rapidly transform frozen blocks of meat or other suitable products such as frozen cheese, into flaked product.**

Eight curved blades rapidly cut scalloped pieces from the frozen block and eject them into a 200 litre bin. Due to a **unique guarding system which closes the discharge chute**, blocks can be queued and then processed without stopping while bins are being replaced.

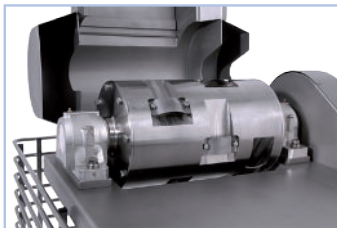

Flaker Drum Assembly

The feed chute is electronically locked during the cutting cycle and can only be opened after the motor has been stopped and a time of 40 seconds has elapsed; this time allows the heavy **Stainless Steel Drum** to come to a complete stop. For safety, the machine cannot be restarted until the feed chute has been closed and locked. Two

lights on the control panel indicate the machine's state, i.e. amber for locked and ready to process product or blue for open in preparation for cleaning.

With the aid of a pneumatic button the ram can also be stopped midway in its stroke to allow the operator to remove any product trapped behind the push bar. With the feed chute opened there is **safe and easy access to the working parts of the machine for cleaning** and sanitation.

This **machine is of robust** construction and the drum has been designed to achieve a satisfactory level of dynamic balance.

## OUTSTANDING FEATURES

- Process blocks of various size up to 600 x 400 x 350
- Process time per block is typically 15seconds
- Increases the performance of Mixer Mincers
- Flake sizes of 5 mm to 10 mm can be obtained (depending on the temperature of the product)
- Easy removal and replacement of cutting blades
- The drum, knives and body of the machine are manufactured from high quality stainless steel ensuring hygiene and easy cleaning.



*The Perfect Companion  
for the Thompson Range of  
Frozen Mixer Mincers.*

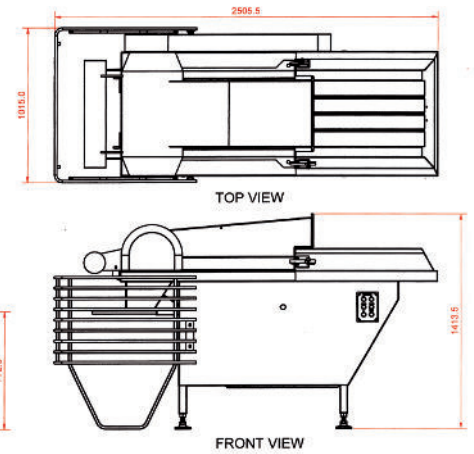

## STANDARD SPECIFICATIONS

Ideally frozen blocks of meat should be processed at a temperature of approx. -12°C (10°F)\*

(\*the temperature may need to be varied, depending on the product being processed)

Motor:	7.5 kW
Volts:	415 V
Full Load Current:	15 Amps
Air Pressure:	60 psi
Net Machine Weight:	800 kg
Ship Weight:	1000 kg
Ship Size (mm):	2500 x 1200 x 1600 H



## THOMPSON MEAT MACHINERY

134 MAGNESIUM DRIVE, CRESTMEAD, QLD AUSTRALIA 4132

PHONE +61 7 3803 6643 – FAX +61 7 3803 6635

EMAIL sales@tmach.com.au – WEB SITE www.tmach.com.au