



Basic industrial model, suitable for medium productions; can bread all sort of products.

Available as optional accessories: speed adjustment for conveyor belts and blower for excess batter.



TECHNICAL FEATURES

- Automatic battering and breading.
- Output: 2,000 to 3,000 pieces per hour.
Variable speed: 9 to 15m. per minute.
- Useful width: 150mm.
- Electrical operation (Single-phase, 220V)
- Motor power: 250 watts.
- Inverter for bread discharge.
- Blower for excess of batter.
- Pieces drop into the belt or go down ramp to remove excess bread.
- Support for trays at exit.
- Mounted on 4 legs with stainless steel wheels.
- Fully dismantlable for easy cleaning.
- Made of stainless steel and non-toxic plastics (suitable for the meat industry).
- Maximum robustness and durability.
- Easy maintenance.
- Budget price.
- Machine weight: 110 kg
- Dimensions of assembled machine: 1,440 x 500 x 1,100mm
- Dimensions of packed machine: 1,300 x 700 x 700mm
- Additionally, the horizontal outlet of breader belt and the turbine can be assembled on the machine to blow the excess of bread on upper surface of product.

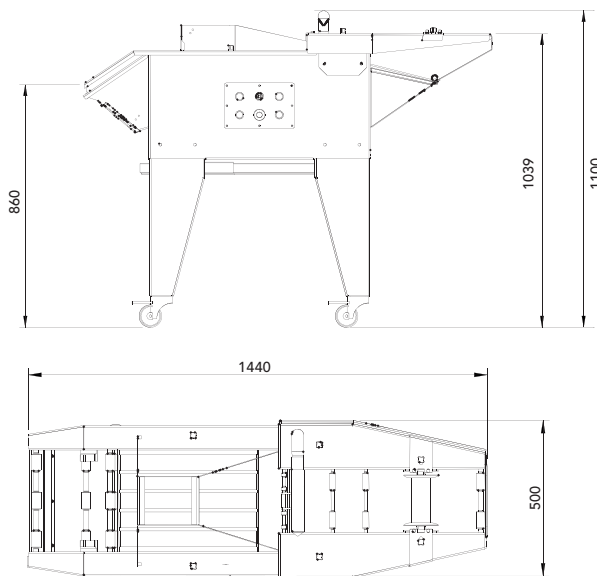

RELATED MACHINES:

- Meatballs former S1500-P, Meatballs & croquettes former S1500-PC, Meatballs & croquettes former mod. DIAPHRAGM GM7000, Hamburger formers, Rotating tables.